

Ansteuerung fuer Drehscheibe, Bühnen-Platine  
 (c) www.digital-bahn.de - Sven Brandt

TITLE: dsd\_buehne\_150

Document Number:	REV: 1v5
------------------	----------

Date: 14.12.2015 15:14	Sheet: 1/3
------------------------	------------



### 3x Optokoppler-Eingänge

z.B. zur Rückmeldung  
der Lok auf der Bühne  
(optional, aber R12/14/16 bestücken)

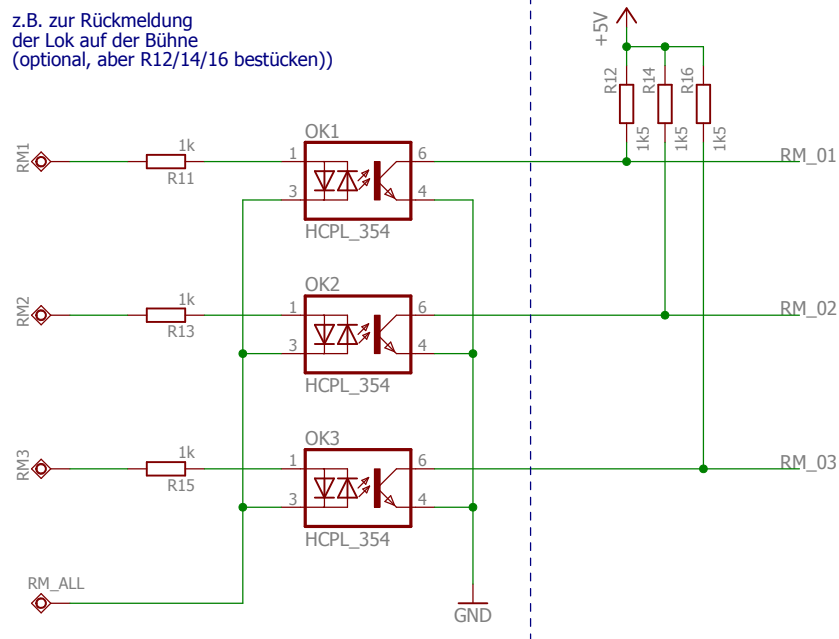

### Hall Sensor

zur Erfassung  
der Null-Position  
(optional, aber R22 bestücken)

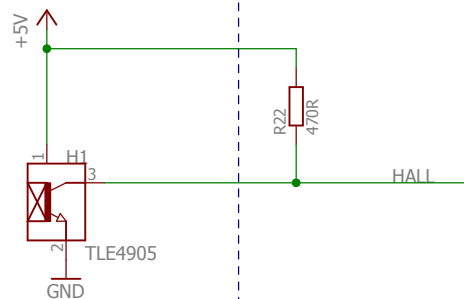

### SUSI Schnittstelle

nur Anbindung eines SUSI  
Sound Moduls  
(optional)

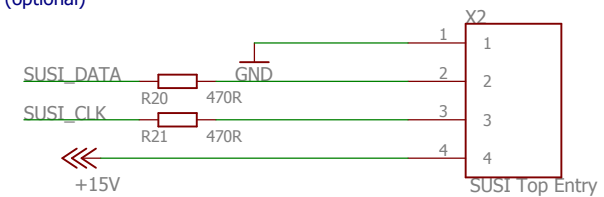

### History:

1v41 - erste Serie  
1v42 - R40/42/44/46 von 1k5 auf 56k (Signal WEISS)  
1v43 - Layout vom K1 auf 3.2 mm coil-contact  
terminal spacing, R5 von 4k7 auf 5k6, C1 in 3x MLCC 1206

Ansteuerung fuer Drehscheibe, Bühnen-Platine  
(c) www.digital-bahn.de - Sven Brandt

CE

WEEE

Digital-Bahn

TITLE: dsd\_buehne\_150

Document Number:

REV:  
1v5

Date: 14.12.2015 15:14

Sheet: 3/3

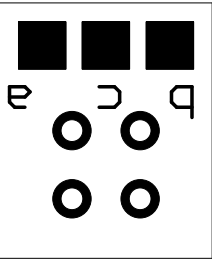
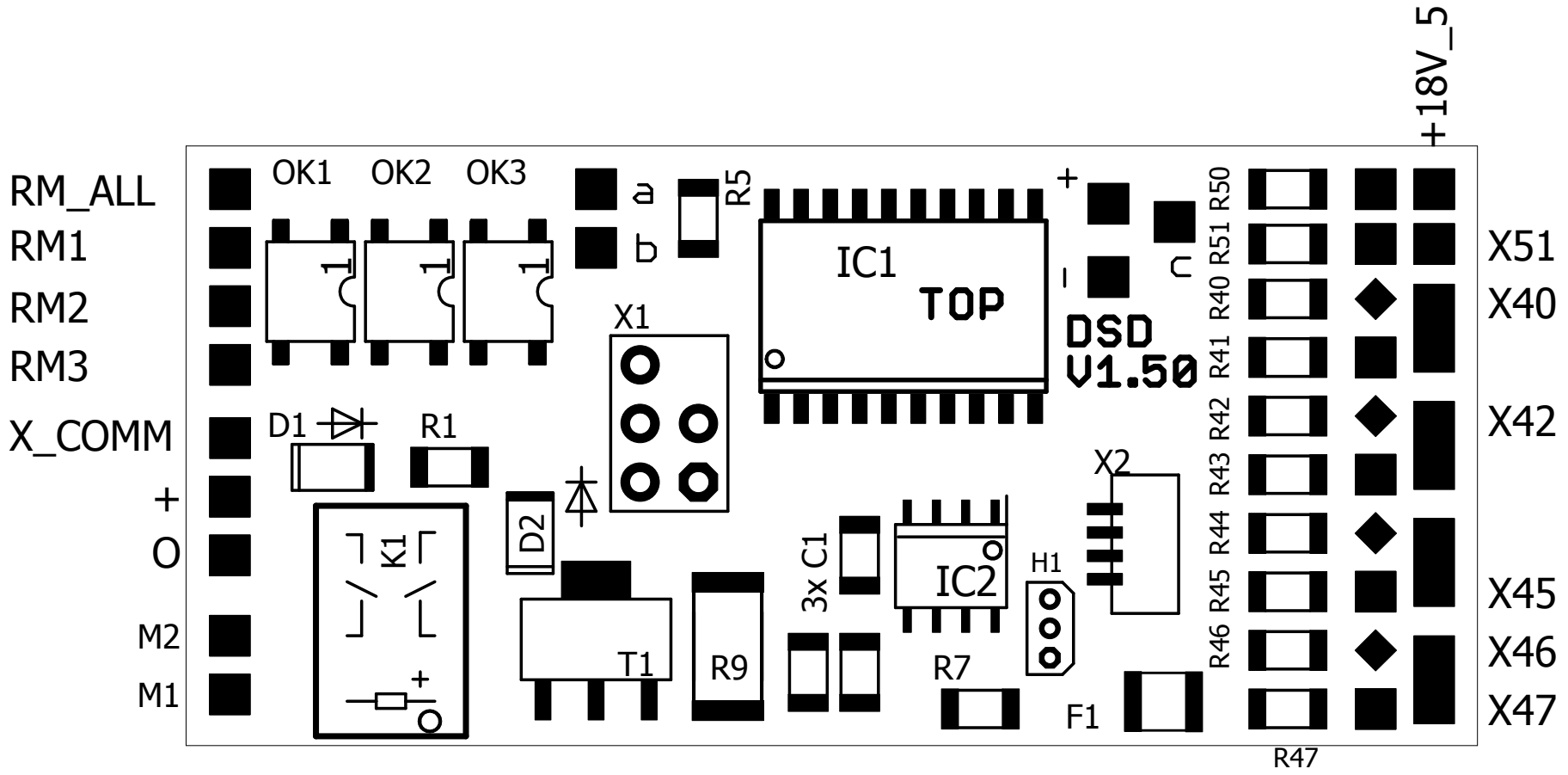

S-LED+  
S-GND  
S-SENSOR

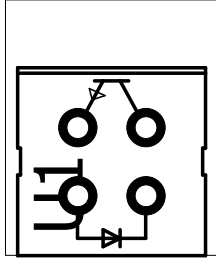

[DIGITAL-BAHN.de](http://DIGITAL-BAHN.de)

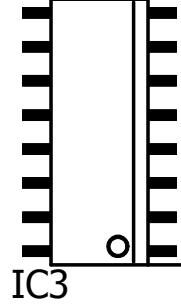

R22

C6

C3

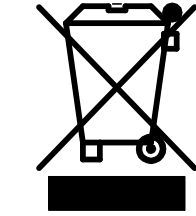
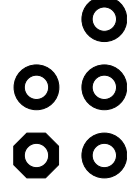
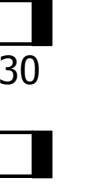
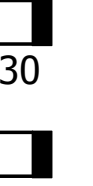

R16



R14



R12



R3



C2



R10



R2



R15



R11

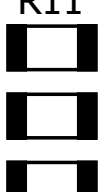

R13



