

DSD2010 - Grube
(c) www.digital-bahn.de - Sven Brandt
TITLE: dsd_grube_1v72
Document Number: REV: V1.72
Date: 11.04.2024 14:50 Sheet: 1/6

Versorgung

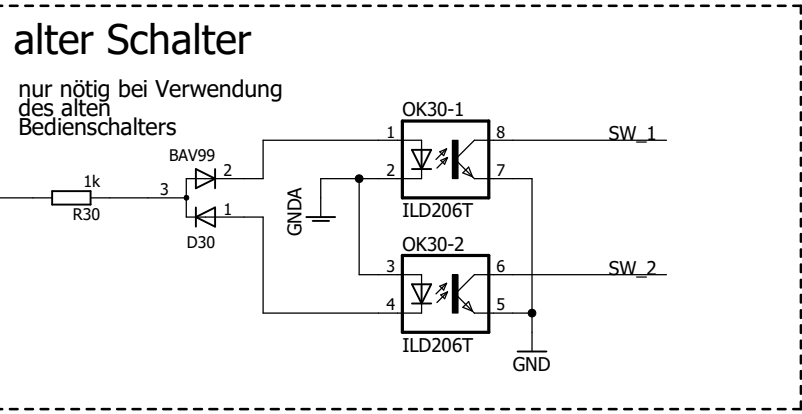

Befehls-Empfang 1

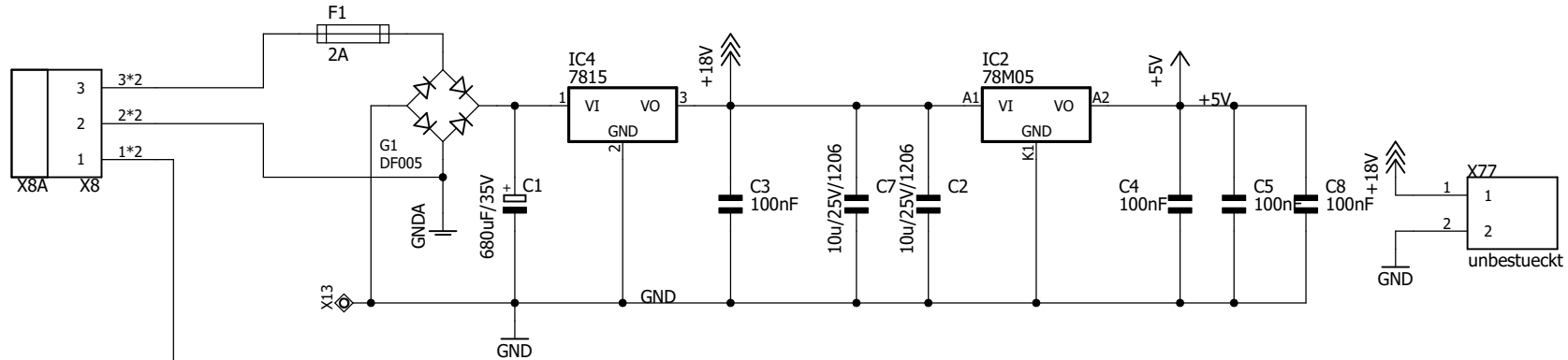
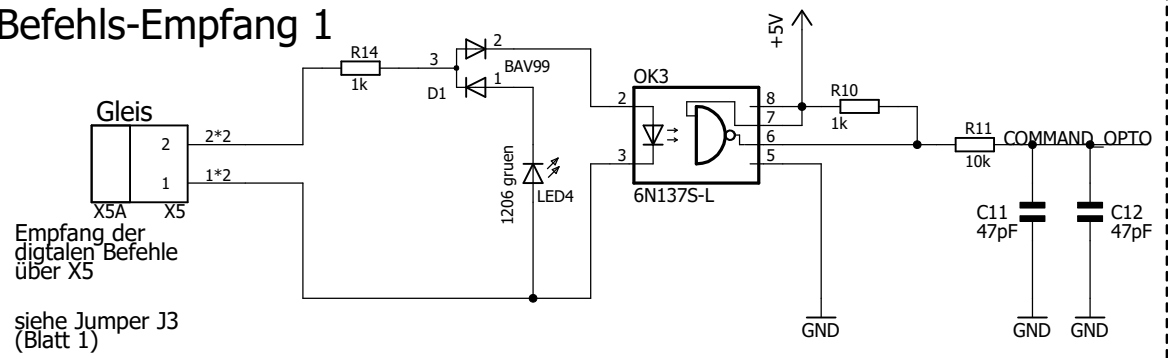

TSH35

DSD2010 - Grube (c) www.digital-bahn.de - Sven Brandt	
TITLE: dsd_grube_1v72	
Document Number:	REU: V1.72
Date: 11.04.2024 14:50	Sheet: 2/6

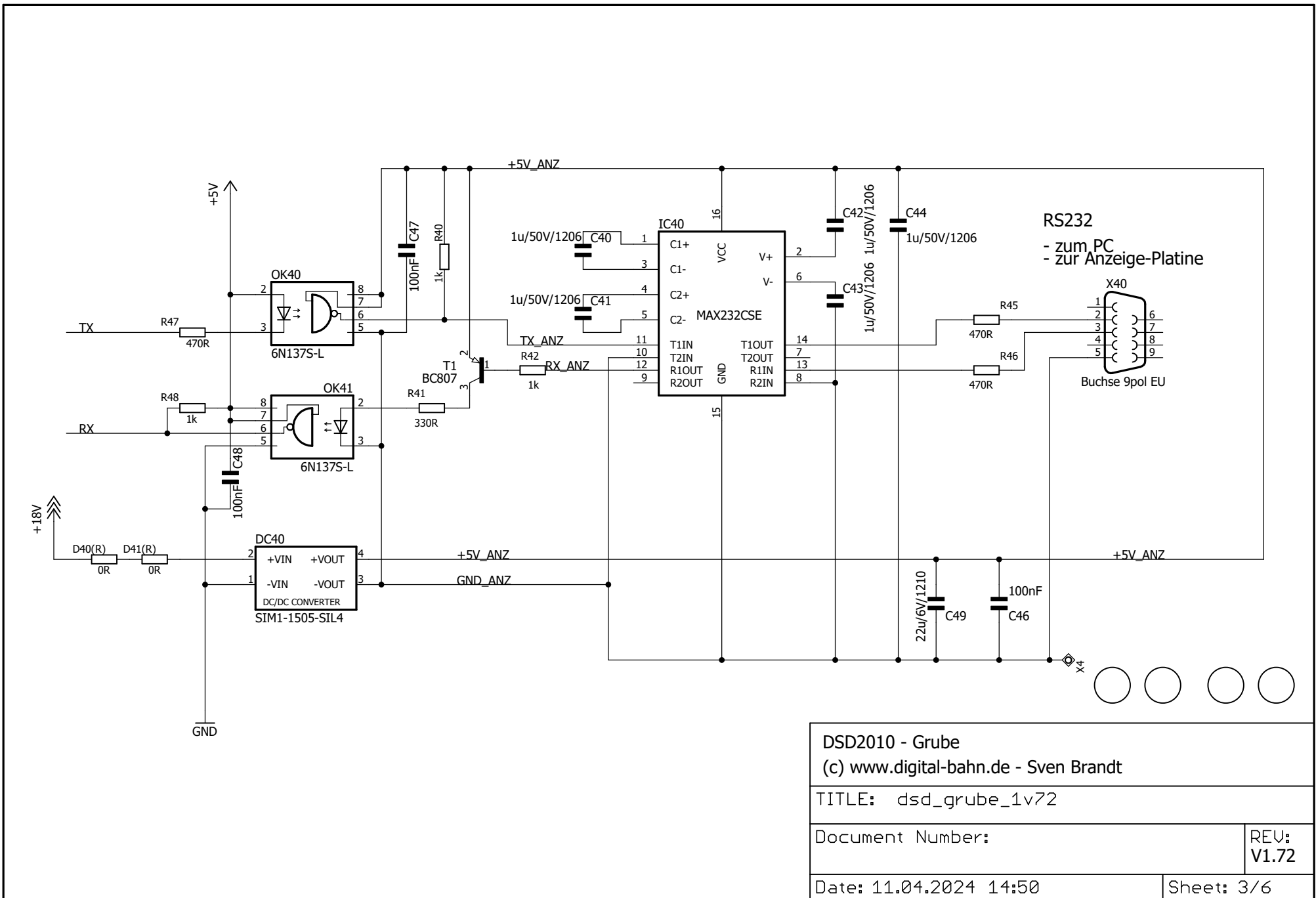

DSD2010 - Grube	
(c) www.digital-bahn.de - Sven Brandt	
TITLE: dsd_grube_1v72	
Document Number:	REU: V1.72
Date: 11.04.2024 14:50	Sheet: 3/6

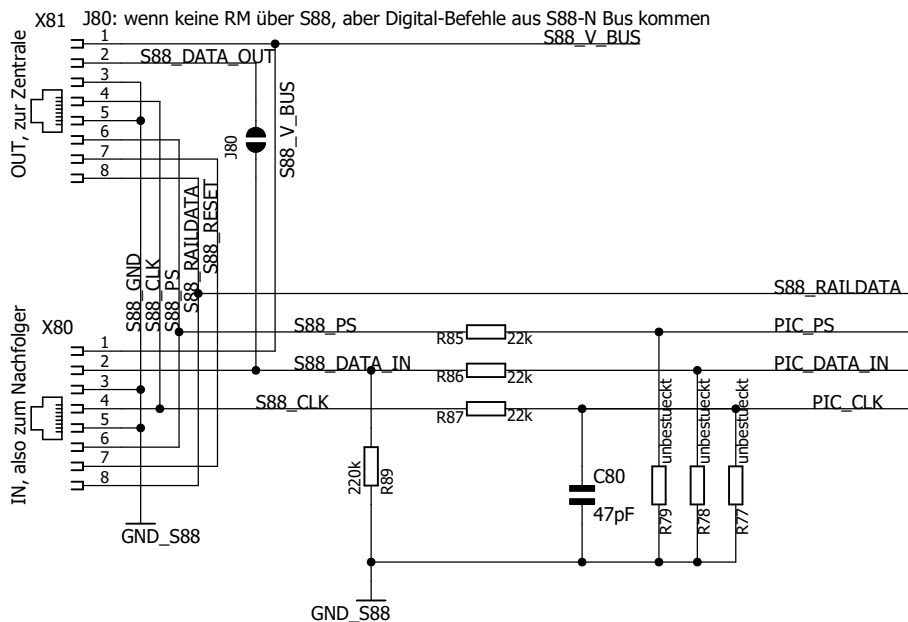
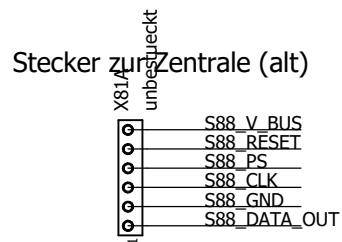

Spg.-Versorgung S88

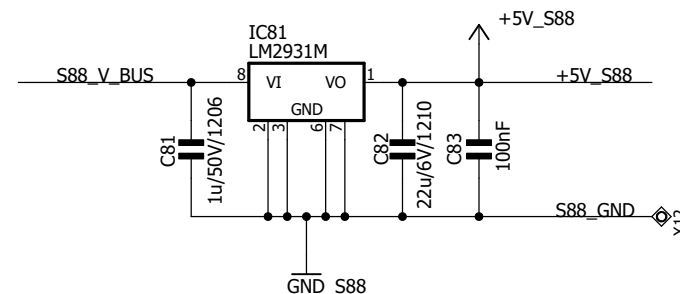

Data-Out (invert. auf Busspannung)

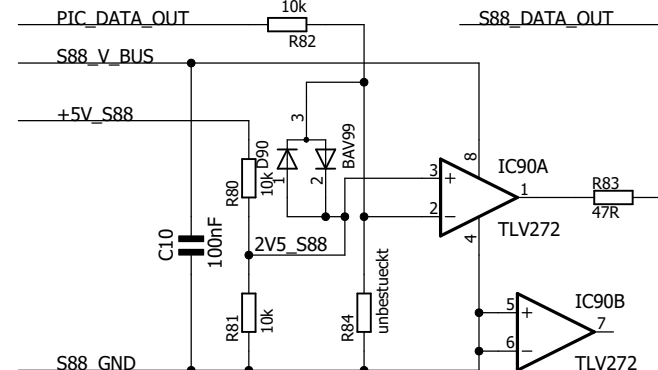

DSD2010 - Grube
 (c) www.digital-bahn.de - Sven Brandt

TITLE: dsd_grube_1v72

Document Number:

REU:
V1.72

Date: 11.04.2024 14:50

Sheet: 5/6

WEEE

Digital-Bahn

CE

History:

V1.60 (2018-02)

- 78L05 in 78M05, 7818 in SMD Variante
- Kondensatoren: Tantal in MLCC / THT in SMD
- Stecker X3 für RM-Modul hinzu (Versorgungsspannung +18V)
- 4x Opto 6N137 in SMD Version / 3x Opto ILD74 in SMD Version
- C8 / C47 hinzu (100 nF)
- C12 hinzu
- Taster entfernt, da keine Funktion
- R2 in 1k5 (war 22k), C6 in 1nF (war 47pF) wg. Problem Kommunikation bei langen Kabeln
- F2 hinzu
- ULN weg, Opto S88 direkt am PIC (Signal-Polarität geändert!), Relais via BC817, Freilauf-Diode hinzu

V1.70 (2019-02)

- Rückkanal S88 (Future)
- Multifuse Gleisspannung hinzu

V1.71 (2023-09)

- X77/X90/X81A/OK83 -> unbestückt
- D40/D41 -> Widerstand 0R
- IC 4: 7818 -> 7815

V1.71 (2023-12)

- F1: 1A -> 2A

V1.72 (2024-01)

- MAX232A -> MAX232 inkl. Anpassung der nötigen Kondensatoren

DSD2010 - Grube

(c) www.digital-bahn.de - Sven Brandt

TITLE: dsd_grube_1v72

Document Number:

REU:
V1.72

Date: 11.04.2024 14:50

Sheet: 6/6

